

SCOUT55

Measuring Amplifier
portabel in desktop
housing

Special features

- 4.8 kHz carrier-frequency amplifier for S.G. half and full bridges, inductive half and full bridges, LVDT, piezoresistive and potentiometric transducers
- Complete control in operator dialogues over the LCD display
- Analog output (current / voltage)
- Four limit value switches
- Peak value stores (Min, Max, Peak-to-Peak) and envelope function, instantaneous values
- Manageable housing with mounting frame/carrying handle
- Serial interface for measurement output and for full parameterisation



Block diagram

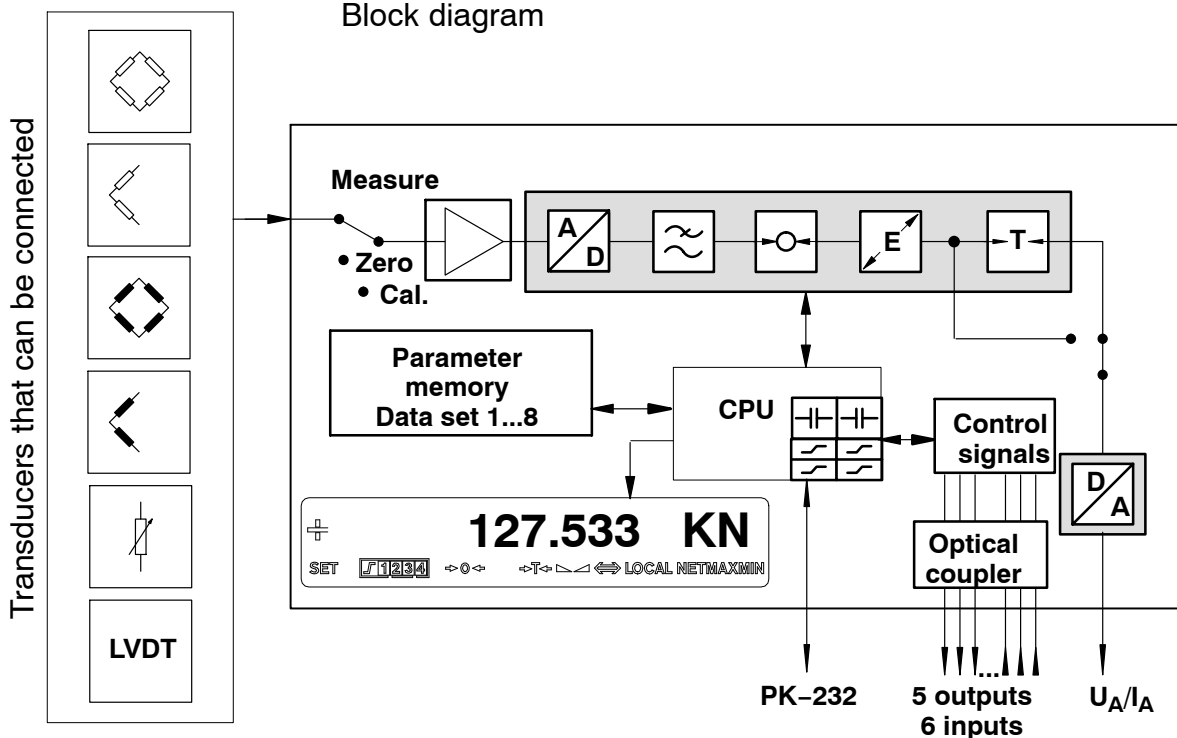

Specifications

Type		SCOUT 55					
Accuracy class		0.1					
Mains connection / Supply voltage	V Hz	115/230, +6 %; -14 %; 48...60					
Power consumption, max.	VA	8					
Safety fuse (slow blowing)	mA	T 125 mA L (115 V) / T 63 mA L (230 V)					
Amplifier							
Carrier frequency	Hz	4800 ± 0.32					
Excitation voltage U_B (± 5 %)	V_{rms}	1 or 2.5					
Transducers that can be connected		$U_B = 1 V_{rms}$					
S.G. half and full bridge	Ω	40...5000					
Inductive half and full bridge, LVDT's	mH	6...19					
		$U_B = 2.5 V_{rms}$					
		80...5000					
		2.5...20					
Permissible cable length between transducer and amplifier	m	max. 500					
Measurement frequency range, adjustable (-1 dB)	Hz	0.05...500					
Input level		low	medium	high			
Measuring range	$U_B=2.5 V$	mV/V	0.2...4	2...40	20...400		
	$U_B=1 V$	mV/V	0.5...10	5...100	50...1000		
Bridge balance range	$U_B=2.5 V$	mV/V	± 4	± 40	± 400		
	$U_B=1 V$	mV/V	± 10	± 100	± 1000		
Noise voltage ¹⁾	0...200 Hz	μV/V _{PP}	0.5	1	10		
	0...1.25 Hz	μV/V _{PP}	0.025	0.1	1		
Effect of 10 K change in ambient temperature¹⁾							
Autocalibration on / off							
Sensitivity	%	0.04 / 0.1	0.04 / 0.1	0.04/0.1			
Zero point	μV/V	0.2/2	2/20	20/200			
Measurement frequency range							
Butterworth low-pass		Nom. val. fc (Hz)	-1 dB (Hz)	-3 dB (Hz)	Phase del. (ms)	Rise time (ms)	Overshoot (%)
		1000	1010	1165	0.66	0.35	12
		500	485	580	1.1	0.7	12
		200	245	290	1.7	1.3	11
		80	78	98	4.3	3.8	10
		40	38	50	7.1	7.3	8
		20	19	26	12	14	7
		10	9.1	12.5	22	28	6
		5	4.6	6.3	41	56	5
Bessel low pass		Nom. val. fc (Hz)	-1 dB (Hz)	-3 dB (Hz)	Phase del. (ms)	Rise time (ms)	Overshoot (%)
		900	900	1550	0.49	0.28	4.1
		400	400	750	0.8	0.6	2
		200	215	395	1.3	1.0	2
		100	111	190	2.5	2.1	2.5
		40	39	68	5	5.5	1.1
		20	21	37	8.1	10	1
		10	11	19	14	19	0.7
		5	5.3	9.7	25	38	0.3
		2.5	2.7	4.9	48	75	0
		1.25	1.4	2.4	90	150	0
		0.5	0.7	1.2	180	300	0
		0.2	0.17	0.3	700	1200	0
		0.1	0.09	0.16	1400	2300	0
		0.05	0.044	0.075	2900	4700	0
Max. permissible common-mode voltage	V	± 5 V					
Common-mode rejection	dB	typically 110					
Max. differential voltage DC	V	± 10					
Linearity deviation	%	typically 0.05					
Long-term drift over 48 hours, Meas. range 2 mV/V		Autocalibration on / off					
30 minutes after switching on (warm-up time)	μV/V	<0.2 / <0.4					

¹⁾ For $U_B=2.5 V$, relative to the input

Analogue output		
Applied voltage	V	± 10 V (asymmetric)
Permissible load resistance, min.	kΩ	5
Internal resistance, max.	Ω	1.5
Applied current	mA	± 20; 4...20
Permissible load resistance, max.	Ω	400
Internal resistance, min.	kΩ	100
The analogue output can show gross, net, positive and negative peaks and peak/peak values.		
Interference voltage at the output, typ.	mV _{PP}	4
Residual carrier voltage 38.4 kHz	mV _{PP}	3
Residual carrier voltage 4800 Hz	mV _{PP}	2
Long-term drift (over 48 h) (30 minutes after switching on)	mV	< 3
Effect of 10 K change in ambient temperature (additional effect to digital value)		
Zero point	mV	< 3
Sensitivity	%	< 0.05
Limit value switch		
Number		4
Reference level	V	Gross, Net, Peak value
Reference voltage (independently adjustable)	V	-10 ... +10
Factory settings, hysteresis	V	0.1
Adjustment accuracy	mV	0.33
Response time	ms	0.83
(all Butterworth filter frequencies and Bessel filters >1.25 Hz. The values double each time for the next lower measurement frequency)		
Peak value stores		
Number		2
Function		positive; negative; peak-to-peak
Update rate	ms	0.03 (with Butterworth filter and Bessel filter ≥ 100 Hz)
Clearing the peak value store	ms	3.3 (control inputs)
Recording of the current value/peak value	ms	3.3 (control inputs)
Time constant for envelopes	ms	100 ... 60 000 (± 6 %)
Control outputs (limit value 1...4, Warning V_{CTRL})		
Nominal voltage, external power supply	V	5
Permissible supply voltage range	V	24
Output current, max.	A	11...30
Short-circuit current, typ.	A	0.5
Short-circuit period		0.8
Isolation voltage, without transients	V _{rms}	unlimited
Control inputs		
Input voltage range, LOW	V	6
Input voltage range, HIGH	V	0...5
Input current, typ., HIGH level = 24 V	mA	10...24
		12

Interface Measuring rate, ASCII output Binary output Number of data bits Baud rate Parity Stop bit	MEAS/S MEAS/S Bit Baud	approx. 25 approx. 50 8 300, 600, 1200, 2400, 4800, 9600 ¹⁾ odd, even ¹⁾ and no ¹⁾ ; 2
Parameter memory (EEPROM)		8 (parameter sets)
Display Number of digits Character height Type Keyboard Dialogue languages Standard	mm	± 10 (16-segment, plus var. special characters) 12.5 LCD (inverse with LED background lighting) Touch-sensitive keypad with 7 button elements on the printed circuit board German / English / French / Italian / Spanish
Effect of operating voltage in the case of changes in the specified range, relative to the full scale on zero point on sensitivity Nominal temperature range Operating temperature range Storage temperature range Degree of protection acc. to DIN IEC 60 529 Protection class Dimensions, over all (W x H x D) Weight, approx.	% % °C °C °C mm kg	0.01 0.01 -20...+50 -20...+50 -20...+70 IP40 (complete device) IP51 (front, touch-sensitive keypad) I 176 x 98 x 211.6 1.88

1) Factory settings

Back side of the device

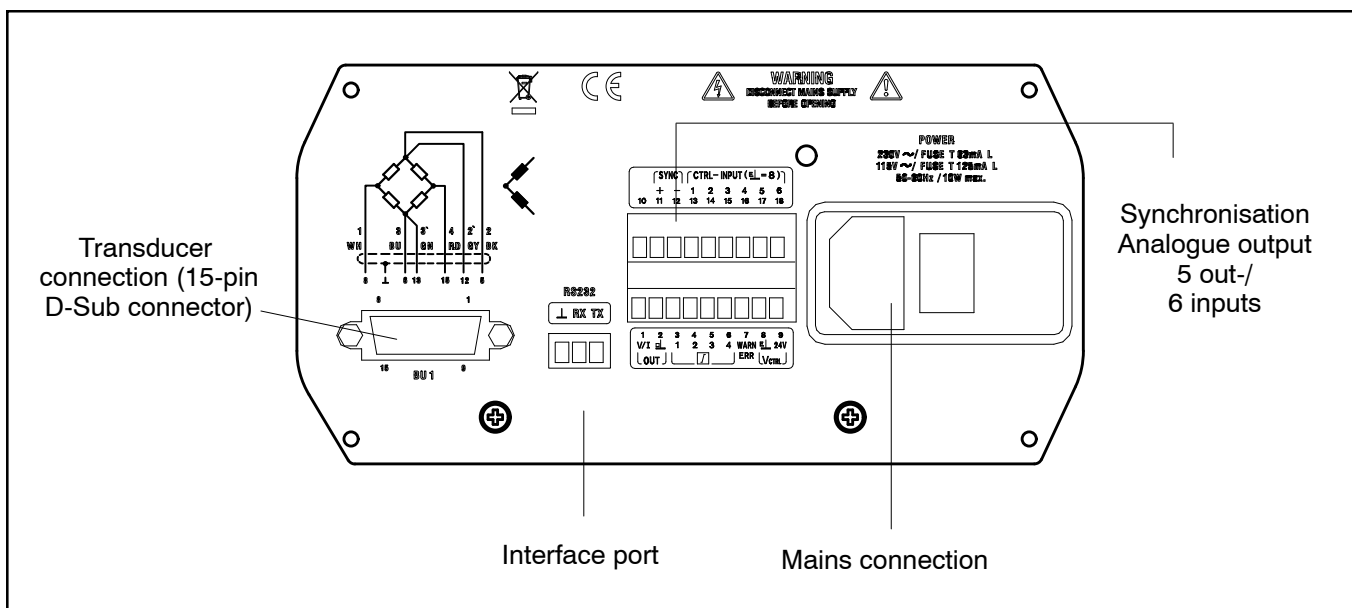

©Hottinger Baldwin Messtechnik GmbH.
 Subject to modifications. All product descriptions are for general information only. They are not to be understood as a guarantee of quality or durability.

托驰 (上海) 工业传感器有限公司
 上海市嘉定区华江路348号1号楼707室
 电话: +86 021 51069888
 传真: +86 021 51069009
 邮箱: zhang@yanatoo.com
 网址: www.sensor-hbm.com

measure and predict with confidence

