

# BU18

Build-up system for  
force measurement



## Special features

- Measurement of compressive forces
- Nominal (rated) force 3 MN
- Based on 3 force transducers (1 MN), for subsequent measurements on calibration machines with lower nominal (rated) forces
- Complete with all force application parts
- Compact, weight and space-saving design
- Class 00 to ISO 376 (in combination with PTB calibration certificate)

## Principle Build-up system BU18

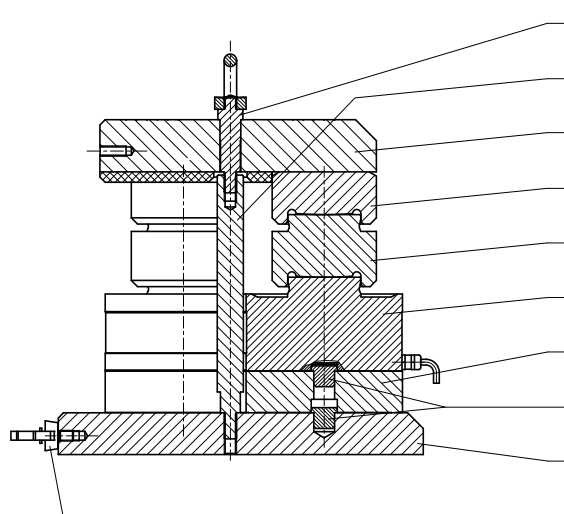

Centering bolt with eye nut x 1

Lifting anchor x 1

BU18 top plate with  
guide element x 1

Thrust piece x 3

Pendulum x 3

C18/1MN force transducers x 3

C18 mounting base x 3

Centering bolts x 6

BU18 mounting base x 1

Rotating eyebolt x 3

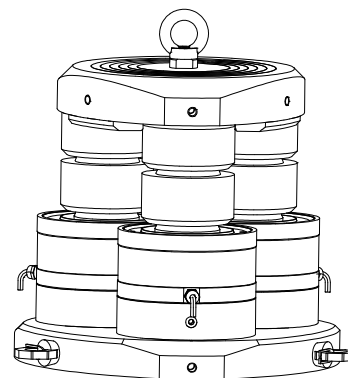

## Specifications BU18/3MN

Type	BU18 / 3 MN		
Data per VDI 2638 and ISO 376			
Nominal (rated) force	$F_{nom}$	kN	3000
Class under ISO 376 ( $0.2 F_{nom}$ to $F_{nom}$ )	00 <sup>1)</sup>		
Nominal (rated) sensitivity	$C_{nom}$	mV/V	2
Rel. sensitivity deviation	$d_c$	%	$< \pm 0,1$
Rel. deviation from zero	$d_{s,o}$	mV/V	$< \pm 1$
<b>Relative reproducibility and repeatability errors (<math>0.2F_{nom}</math> to <math>F_{nom}</math>) for:</b>			
a constant mounting position	$b'$	%	$< \pm 0,015$
varying mounting positions	$b$	%	$< \pm 0,04$
Relative deviation from fitting curve ( $0.2F_{nom}$ to $F_{nom}$ )	$f_c$	%	$< \pm 0,02$
Relative zero error (zero signal return)	$f_o$	%	$< \pm 0,008$
Relative reversibility error ( $0.2F_{nom}$ to $F_{nom}$ )	$v$	%	$< \pm 0,06$
Relative linearity error	$d_{lin}$	%	$< \pm 0,025$
Effect of temperature on sensitivity, per 10 K, related to nominal (rated) sensitivity	$TK_c$	%	$< \pm 0,01$
Effect of temperature on zero signal per 10 K, related to nominal (rated) sensitivity	$TK_0$	%	$< \pm 0,01$
Relative creep over 30 min	$d_{crF+E}$	%	$< \pm 0,03$
Effect of lateral forces (lateral force 10% $F_{nom}$ )	$d_Q$	%	$< 0,1$
Effect of eccentricity per mm	$d_E$	%	$< 0,02$
Input resistance	$R_i$	$\Omega$	$4450 \pm 100$
Output resistance	$R_o$	$\Omega$	$4010 \pm 2$
Insulation resistance	$R_{is}$	$\Omega$	$> 50 \times 10^9$
Reference excitation voltage	$U_{ref}$	V	5
Operating range of the excitation voltage	$B_{U,G}$	V	5...30
Carrier frequency of excitation voltage		Hz	$< 600$
Nominal (rated) temperature range	$B_{t,nom}$	$^{\circ}C$	+10 ... +40
Operating temperature range	$B_{t,G}$	$^{\circ}C$	-30 ... +80
Storage temperature range	$B_{t,S}$	$^{\circ}C$	-50 ... +85
Reference temperature	$t_{ref}$	$^{\circ}C$	+22
Max. operating force	$(F_G)$	%	170
Limit force	$(F_L)$	%	170
Breaking force	$(F_B)$	%	400
Permissible horizontal displacement of top plate	$e_G$	mm	$< \pm 2$
Nominal (rated) displacement	$S_{nom}$	mm	0.45
Weight (with VKK, without carrying case)		kg	107
Degree of protection per DIN 60529			IP53

<sup>1)</sup> Classification only guaranteed in conjunction with a PTB calibration certificate to ISO 376.

## Specifications C18-S1/1MN

Type	C18-S1 / 1 MN		C18-S1 / 1 MN
Data per VDI 2638 and ISO 376			
Nominal (rated) force	$F_{nom}$	kN	1000
Class under ISO 376 ( $0.2 F_{nom}$ to $F_{nom}$ )	00 <sup>1)</sup>		
Nominal (rated) sensitivity	$C_{nom}$	mV/V	2
Rel. sensitivity deviation	$d_c$	%	$< \pm 0.1$
Rel. deviation from zero	$d_{s,o}$	mV/V	$< \pm 1$
<b>Relative reproducibility and repeatability errors (<math>0.2F_{nom}</math> to <math>F_{nom}</math>) for:</b>			
a constant mounting position	$b'$	%	$< \pm 0.015$
varying mounting positions	$b$	%	$< \pm 0.04$
Relative deviation from fitting curve ( $0.2F_{nom}$ to $F_{nom}$ )	$f_c$	%	$< \pm 0.02$
Relative zero error (zero signal return)	$f_o$	%	$< \pm 0.008$
Relative reversibility error ( $0.2F_{nom}$ to $F_{nom}$ )	$v$	%	$< \pm 0.06$
Relative linearity error	$d_{lin}$	%	$< \pm 0.025$
Effect of temperature on sensitivity, per 10 K, related to nominal (rated) sensitivity	$TK_c$	%	$< \pm 0.01$
Effect of temperature on zero signal, per 10 K, related to nominal (rated) sensitivity	$TK_0$	%	$< \pm 0,01$
Relative creep over 30 min	$d_{crF+E}$	%	$< \pm 0,03$
Effect of lateral forces (lateral force 10 % $F_{nom}$ )	$d_Q$	%	$< 0,1$
Effect of eccentricity per mm	$d_E$	%	$< 0,02$
Input resistance	$R_i$	$\Omega$	$4450 \pm 100$
Output resistance	$R_o$	$\Omega$	$4010 \pm 2$
Insulation resistance	$R_{is}$	$\Omega$	$> 50 \cdot 10^9$
Reference excitation voltage	$U_{ref}$	V	5
Operating range of the excitation voltage	$B_{U,G}$	V	5...30
Carrier frequency of excitation voltage		Hz	$< 600$
Nominal (rated) temperature range	$B_{t,nom}$	$^{\circ}C$	+10...+40
Operating temperature range	$B_{t,G}$	$^{\circ}C$	-30...+80
Storage temperature range	$B_{t,S}$	$^{\circ}C$	-50...+85
Reference temperature	$t_{ref}$	$^{\circ}C$	+22
Max. operating force	$(F_G)$	%	170
Limit force	$(F_L)$	%	170
Breaking force	$(F_B)$	%	400
Nominal (rated) displacement	$S_{nom}$	mm	0,45
Rel. permissible oscillatory stress	$F_{rb}$	%	70
Weight		kg	approx. 15.3
Degree of protection per DIN 60529			IP68
Cable length four-wire configuration with fitted Fischer S103 A057-130 plug		m	1

1) Classification only guaranteed in conjunction with a PTB calibration certificate to ISO 376.

## BU18/3MN dimensions

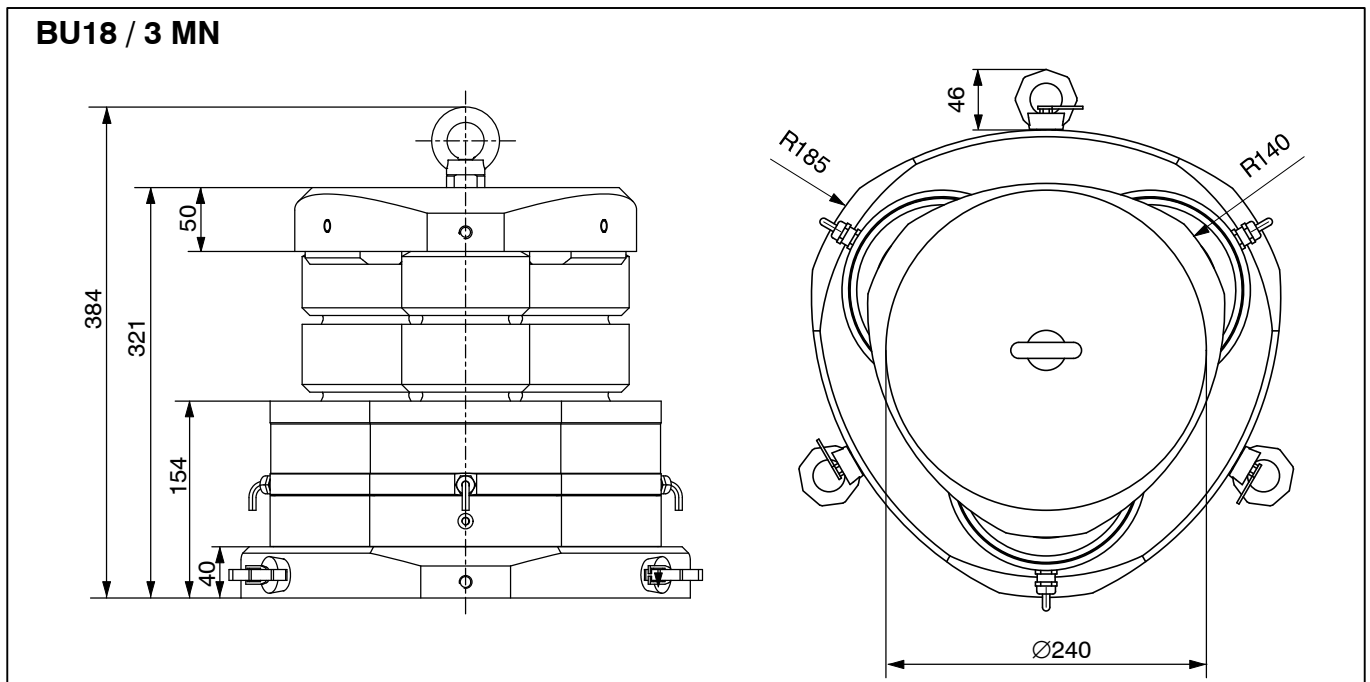

## C18-S1/1MN dimensions

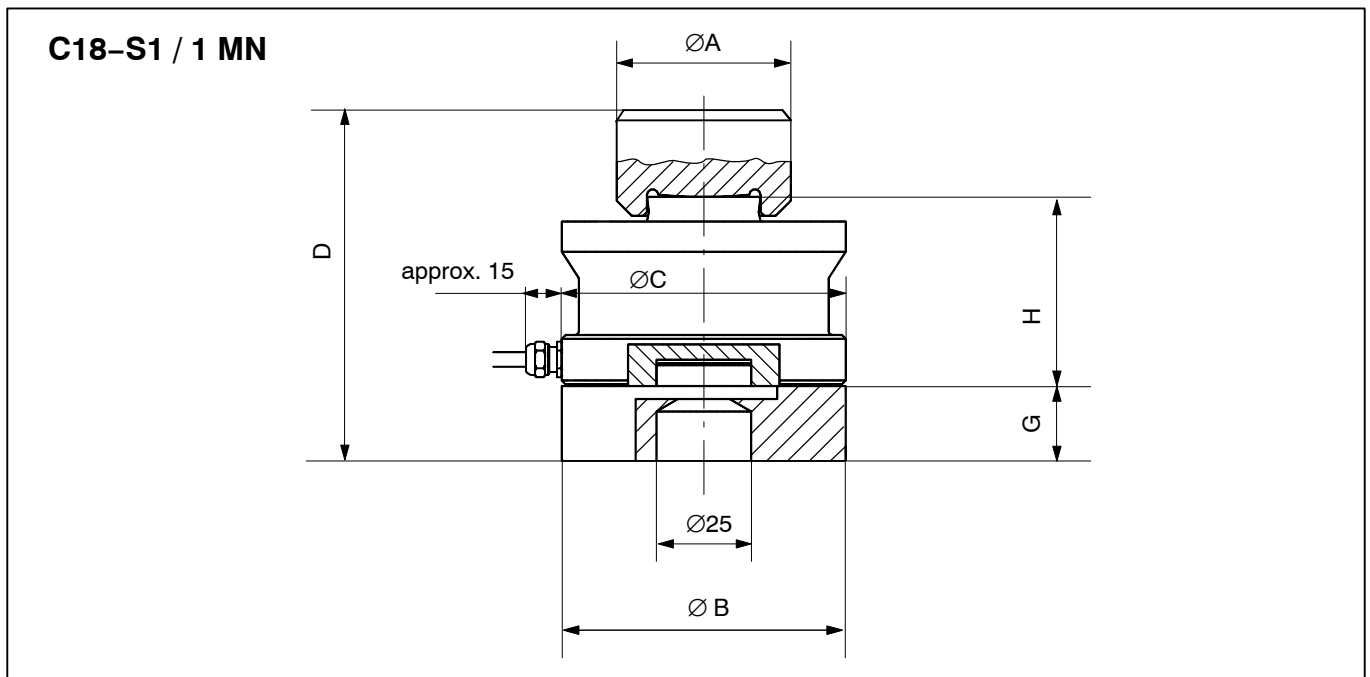

Type	$\varnothing A$	$\varnothing B$	$\varnothing C$	D	G	H
C18 / 1 MN	100	150	150	171	40	90

## Connection

The Build-up system BU18/3MN is supplied complete with all cables and with a distributor box (see data sheet VKK1-4).

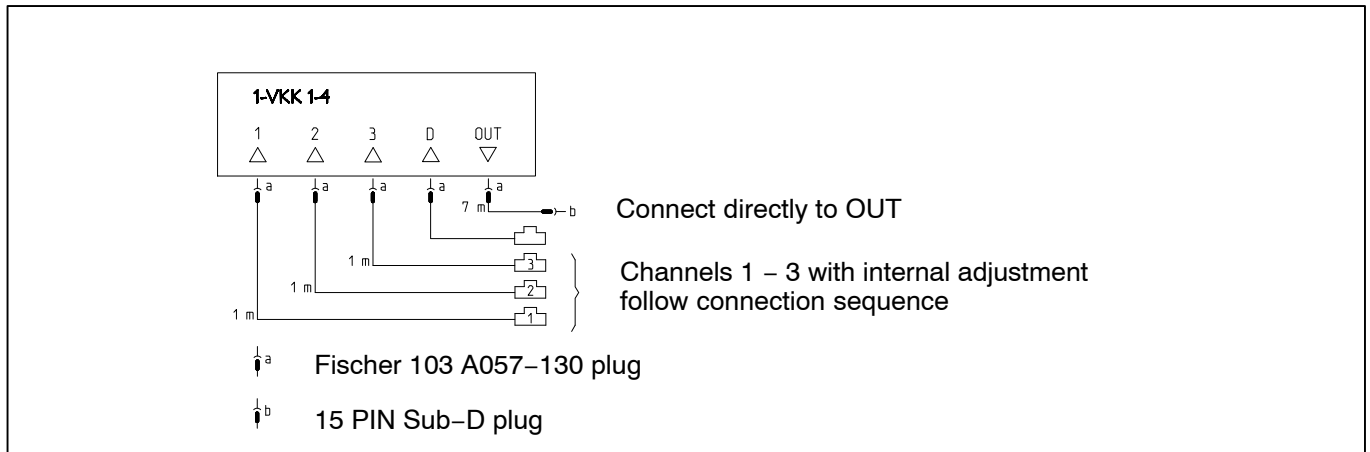

## Scope of supply:

C18-S1/1MN measuring body (Class 00 to ISO 376), 1 m cable with fitted Fischer S103 A057-130 plug	3 units
C18 mounting base	3 units
C18 thrust piece	3 units
Pendulum	3 units
BU18 top plate	1 unit
BU18 mounting base	1 unit
Centering bolts	6 units
Centering bolt with eye nut	1 unit
Eyebolt	1 unit
Ring bolts, rotating, including wrench	3 units
Distributor box with Fischer K103 A057-130 socket	1 unit
Extension cable six-wire configuration, 5 m, Fischer K103 A057-130 socket and 15-pin D-Sub plug	1 unit
Connection cable six-wire configuration, 7m, Fischer S103 A057-130 plug and 15-pin D-Sub plug	1 unit
Carrying case with chassis	1 unit

## Accessories:

PTB calibration certificate to ISO 376; up to 5 MN; calibrated in the compression direction

K-CAL-FD7DS

Modifications reserved.  
All details describe our products in general form only. They are not to be understood as express warranty and do not constitute any liability whatsoever.

B2327-2.0 en

托驰（上海）工业传感器有限公司  
上海市嘉定区华江路348号1号楼707室  
电话: +86 021 51069888  
传真: +86 021 51069009  
邮箱: zhang@yanatoo.com  
网址: www.sensor-hbm.com



measurement with confidence