

C15

Force transducers

Special features

- Compressive force transducer
- Nominal (rated) forces 2.5 kN ... 1 MN
- Class 00 per ISO 376 in the force measurement range between 10% and 100% of the nominal (rated) force
- Electronic eccentricity adjustment
- Double bridge version, TEDS chip and other options
- Accessories available according to ISO 376



Mounting dimensions of connection variants

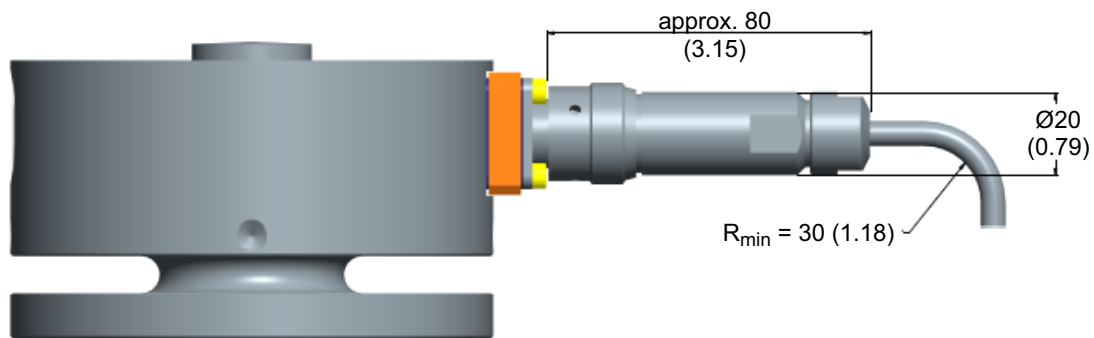

Version with bayonet connector

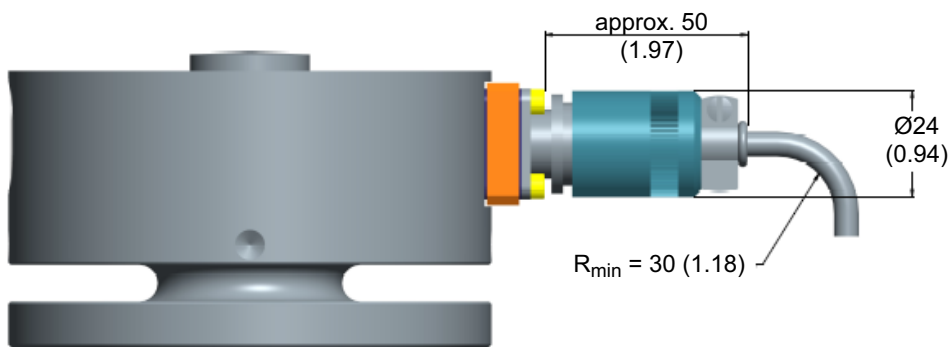

Version with threaded connector

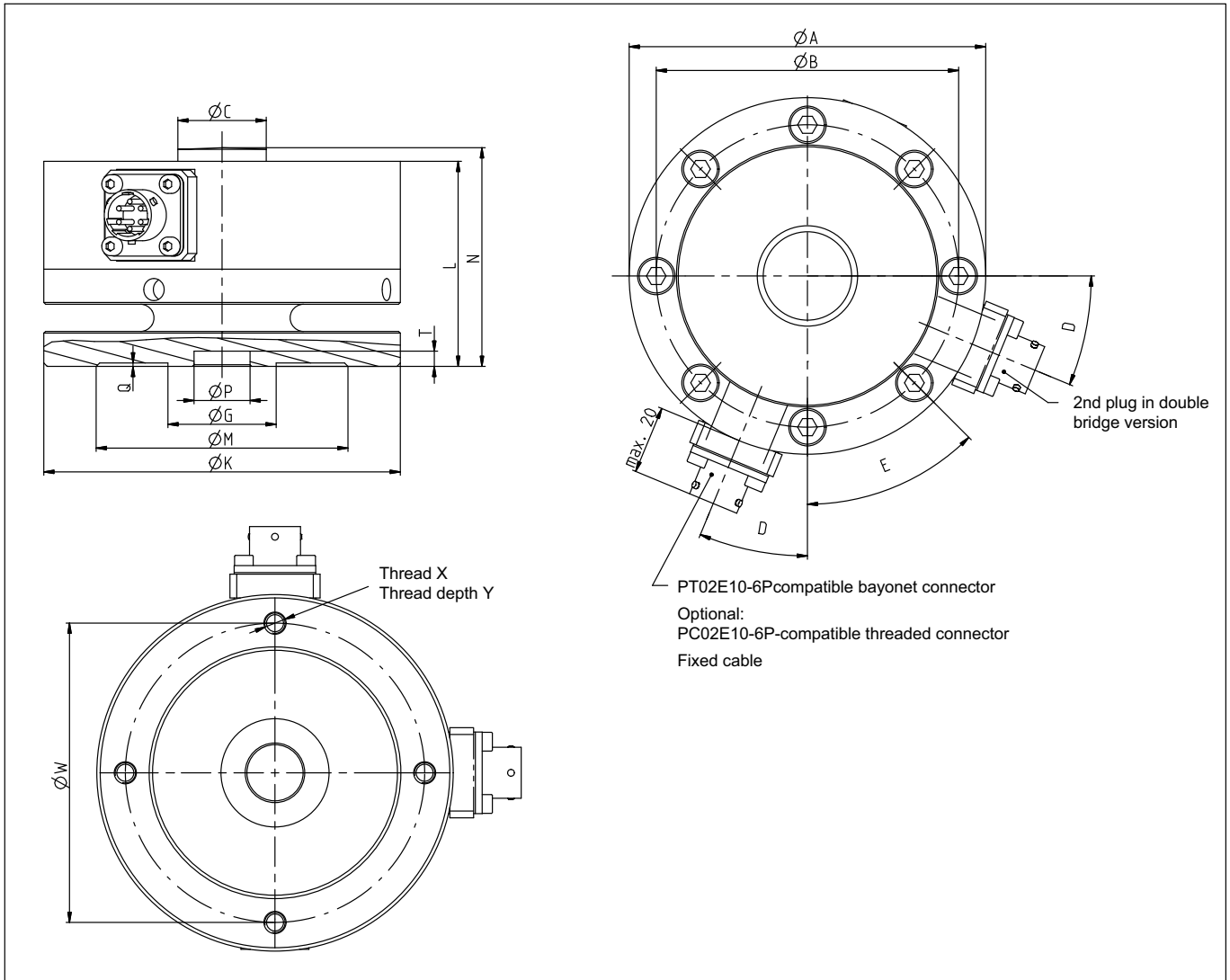

Dimension [unit]	Nominal (rated) force					
	up to 10 kN	25 to 50 kN	100 kN	250 kN	500 kN	1 MN
$\varnothing A$ [mm]	104.8	104.8	153.9	153.9	203.2	279
$\varnothing B$ [mm]	88.9	88.9	130.3	130.3	165.1	229
$\varnothing C$ [mm]	26	26	40	40	64	80
D [°]	22.5	22.5	15	15	11.25	11.25
E [°]	45	45	30	30	22.5	22.5
$\varnothing G$ [mm]	31.8	31.8	57.2	57.2	76.2	114
$\varnothing K$ [mm]	102.8	102.8	151.9	151.9	201.2	277
L [mm]	60.3	60.3	85.9	85.9	108	152.4
$\varnothing M$ [mm]	74	74	113.5	113.5	145	200
N [mm]	64.3	64.3	92	92	116	160.9
$\varnothing P^{H8}$ [mm]	16.5	16.5	33.5	33.5	43	73
Q [mm]	1	1	1	1	1	1
T [mm]	4.5	4.5	4.5	4.5	6	8
$\varnothing W$ [mm]	88	88	132	132	172	238
X	M6	M6	M8	M8	M12	M16
Y [mm]	12	12	16	16	24	32

Specifications

Type	C15										
Nominal (rated) force	F_{nom}	kN	2.5	5	10	25	50	100	250	500	1000
Accuracy data per ISO 376											
Accuracy class per ISO 376			00								
Force measurement range in which the class accuracy per ISO 376 is reached		%	10 ... 100								
Reproducibility (relative reproducibility error in different mounting positions) in the force measurement range 10% ... 100% of F_{nom}	b	%	0.05								
Repeatability (relative repeatability error in unchanged mounting position) in the force measurement range 10% ... 100% of F_{nom}	b'	%	0.01				0.02				
Deviation from the fitting curve (force measurement range: 10%...100% of F_{nom})	f_c	%	0.025								
Zero error	f_0	%	0.012								
Relative reversibility error (force measurement range: 10%...100% of F_{nom})	v	%	0.05				0.07				
Creep	c	%	0.01								
Accuracy											
HBM accuracy class			0.03		0.04		0.05		0.06		
Rel. reproducibility and repeatability errors in unchanged mounting position	$b_{r,g}$	%	0.02								
Rel. reversibility error (hysteresis) at 0.4 F_{nom}	$v_{0.4}$	%	0.03		0.04		0.05		0.06		
Non-linearity	d_{lin}	%	0.03		0.04				0.06		
Relative zero point return		%	0.01								0.02
Relative creep (at room temperature, 30 min)	d_{crF+E}	%	0.02								
Effect of eccentricity	d_e	%/mm	0.04								
Temperature coefficient of sensitivity	TC_S	%/10 K	0.015								
Temperature coefficient of zero signal	TK_0	%/10 K	0.0075								
Electrical values											
Rated output range	C	mV/V	2 ... 3		4 ... 4.8						
Rated output (nominal) (with "Adjusted rated output" option)	C_{nom}	mV/V	2		3						
Characteristic curve deviation with "Adjusted rated output" option	d_c	%	0.1								
Relative zero signal error	$d_{s,0}$	%	1								
Input resistance	R_i	Ω	345								
Output resistance	R_o	Ω	220 ... 360								
Output resistance with "Adjusted rated output" option	R_o	Ω	365 \pm 0.5								
Insulation resistance	R_{is}	Giga Ω	2								
Operating range of the excitation voltage	$B_{U,G}$	V	0.5 ... 12								
Reference excitation voltage	U_{ref}	V	5								
Connection	6-wire circuit										
Temperature											
Reference temperature	T_{ref}	$^{\circ}C$ [$^{\circ}F$]	23 [73.4]								
Nominal (rated) temperature range	$B_{T,nom}$	$^{\circ}C$ [$^{\circ}F$]	-10 ... +45 [14 ... 113]								
Operating temperature range	$B_{T,G}$	$^{\circ}C$ [$^{\circ}F$]	-30 ... +85 [-22 ... 185]								

Nominal (rated) force	F_{nom}	kN	2.5	5	10	25	50	100	250	500	1000
Storage temperature range	$B_{T,S}$	°C [°F]	-30 ... +85 [-22 ... 185]								
Characteristic mechanical quantities											
Maximum operating force	F_G	% of F_{nom}	120								
Force limit	F_L	% of F_{nom}	120								
Breaking force	F_B	% of F_{nom}	200								
Max. eccentricity	e_G	mm	10.2	9.9	9.1	14.1	12	20.6	23.9		
Static lateral force limit	F_q	% of F_{nom}	50								
Nominal (rated) displacement	s_{nom}	mm	0.05	0.06	0.08	0.1	0.08	0.13	0.15	0.18	
Fundamental frequency	f_G	kHz	4.7	6.5	8.6	5.8	8.2	5.7	7.3	5.9	5.4
Relative permissible oscillatory stress	f_{rb}	% of F_{nom}	100								
Stiffness	F/S	10 ⁵ N/mm	0.5	1	1.7	3.1	5	12.5	19.2	33	55.6
General information											
Degree of protection per EN 60529, with bayonet connector (standard version), socket connected to sensor			IP67								
Degree of protection per EN 60529, with "Threaded connector" option			IP64								
Spring element material			Aluminum			Stainless steel					
Measuring point protection			Tightly glued measuring body			Hermetically welded measuring body					
Mechanical impact resistance per IEC 60068-2-6											
Number		n	1000								
Duration		ms	3								
Acceleration		m/s ²	1000								
Vibrational stress per IEC 60068-2-27											
Frequency range		Hz	5 ... 65								
Duration		min	30								
Acceleration		m/s ²	150								
Weight		kg	1.24	3.24	10.7	24.1	67				
		lbs	2.7	7.1	23.6	53.1	147.7				

Plug and cable assignment in six-wire circuit

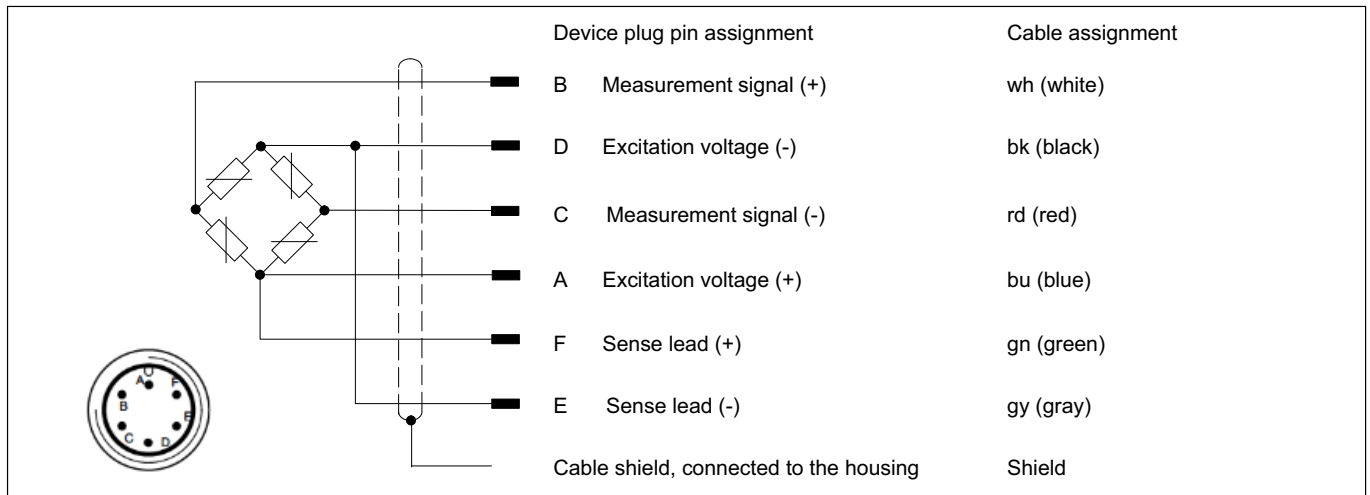

Pin assignment for HBM cables

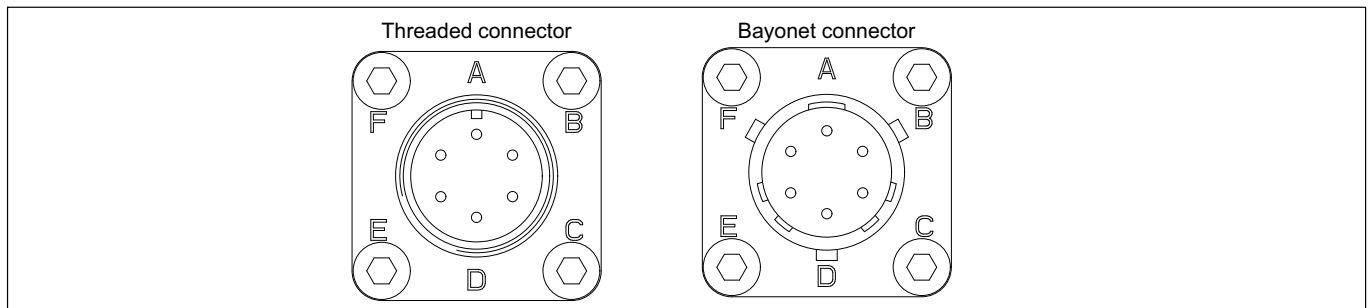

Dimensions of EDO3 thrust piece

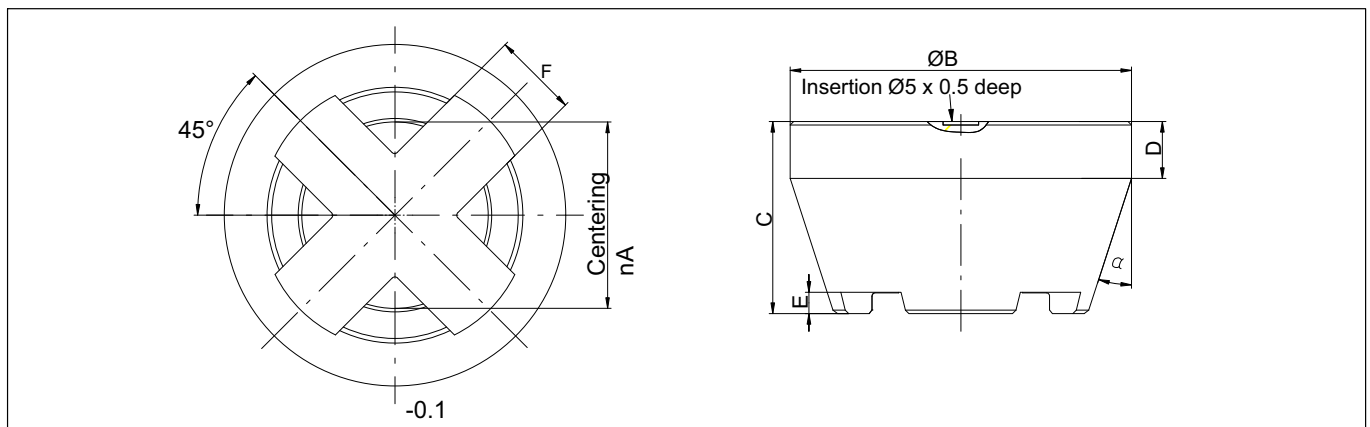

Dimension [unit]	Nominal (rated) force (for 100% calibration)			
	up to 50 kN	100 to 250 kN	500 kN	1 MN
ØA [mm]	26.2	40.2	64.2	80.2
ØB [mm]	48	80	112	130
C [mm]	27	45	62	72
D [mm]	8	10	15	15
E [mm]	3	5	6	6
F [mm]	12	23	30	36
α [°]	18	18	18	18
Ordering number	1-EDO3/50KN	1-EDO3/100KN	1-EDO3/500KN	1-EDO3/1 MN

C15 mounting heights with EDO3 thrust piece

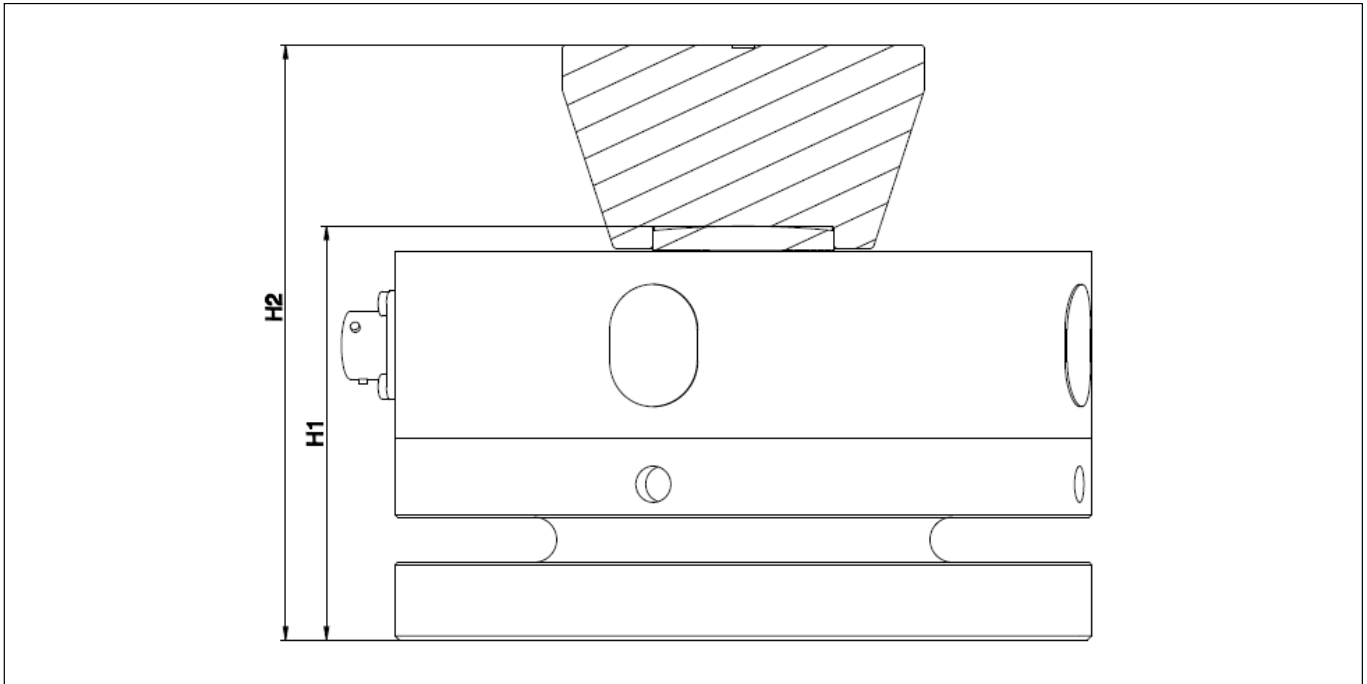

Nominal (rated) force	Height of transducer with adapter, H1 (mm)	Height of transducer, adapter and thrust piece, H2 (mm)
2.5 kN	64.3	88.3
5 kN	64.3	88.3
10 kN	64.3	88.3
25 kN	64.3	88.3
50 kN	64.3	88.3
100 kN	92.0	132.0
250 kN	92.0	132.0
500 kN	116.0	172.0
1 MN	160.9	226.9

C15 versions and ordering numbers

Code	Nominal (rated) force
2k50	2.5 kN
5k00	5 kN
10k0	10 kN
25k0	25 kN
50k0	50 kN
100k	100 kN
250k	250 kN
500k	500 kN
1M00	1 MN

Number of measuring bridges	Transducer identification	Plug protection	Electrical connection		Rated output	
			Bridge A	Bridge B		
Single bridge SB	Without TEDS chip S	Without U	bayonet connector B		Adjusted J	
Double bridge DB	With TEDS chip T	With P	threaded connector G		Not adjusted U	
K-C15-	1M00-	SB-	S-	U-	B-	U

Nominal (rated) force	You can purchase force transducers with nominal (rated) forces between 2.5 kN and 1 MN. The nominal (rated) force is the force at which the sensor provides the rated output specified on the type plate as the output signal.
Number of measuring bridges	You can purchase the force transducer with a single bridge (SB), and then the U15 comes supplied with one measuring bridge. The double-bridge version (DB) is optionally available. In this case the U15 comes with two galvanically isolated bridge circuits so that you can connect two bridge amplifiers working independently of each other.
Transducer identification	You can purchase the force transducer with transducer identification ("TEDS"). A TEDS chip (Transducer Electronic Data Sheet) allows you to store the transducer data (rated outputs) in a chip that can be read by a connected measuring device. Each measuring bridge has a separate TEDS chip in the double bridge variant. For more detailed information refer to the operating manual.
Plug protection	On request, we can fit plug protection, consisting of a strong square tube, so that the plug is protected against mechanical damage.
Electrical connection bridge A	The standard version is the device plug with a bayonet connection (PT02E 10-6P-compatible). You also have the option of ordering a device plug with a screw thread (PC02E 10-6P-compatible).
Electrical connection bridge B	The standard version is the device plug with bayonet locking (PT02E 10-6P-compatible). You also optionally order a screw device plug (PC02E 10-6P-compatible).
Rated output	The exact rated output is always stated on the type plate and on the enclosed test record. On request, the transducer can be adjusted at the factory to a rated output of 2 mV/V (all force transducers with nominal (rated) forces up to and including 10 kN) or 3 mV/V (all force transducers with nominal (rated) forces greater than 10 kN). The rated output range of a transducer that has not been adjusted lies between 2 and 3 mV/V (all force transducers with nominal (rated) forces up to and including 10 kN) or between 4 and 4.8 mV/V (all force transducers with nominal (rated) forces greater than 10 kN). Please note the input range for your amplifier.

Accessories (not included in the scope of supply)

Connection cable/ground cable/thrust pieces	Ordering number
Configurable connection cable for connecting the force transducer to the bridge amplifier.	K-CAB-F
Connection cable KAB157-3; IP67 (with bayonet locking); 3 m long, TPE outer sheath; 6 x 0.25 mm ² ; free ends, shielded, outside diameter 6.5 mm	1-KAB157-3
Connection cable KAB158-3; IP54 (with screw locking); 3 m long, TPE outer sheath; 6 x 0.25 mm ² ; free ends, shielded, outside diameter 6.5 mm	1-KAB158-3
Loose cable socket (bayonet connection)	3-3312.0382
Loose cable socket (screw connection)	3-3312.0354
Ground cable, 400 mm long	1-EEK4
Ground cable, 600 mm long	1-EEK6
Ground cable, 800 mm long	1-EEK8
Thrust piece to ISO376, suitable for C15 with nominal (rated) forces from 2.5 kN to 50 kN	1-EDO3/50KN
Thrust piece to ISO376, suitable for C15 with nominal (rated) forces 100 kN and 250 kN	1-EDO3/100KN
Thrust piece to ISO376, suitable for C15 with nominal (rated) force 500 kN	1-EDO3/500KN
Thrust piece to ISO376, suitable for C15 with nominal (rated) force 1 MN	1-EDO3/1 MN

Subject to modifications.
All product descriptions are for general information only. They are not to be understood as a guarantee of quality or durability.

托驰 (上海) 工业传感器有限公司
上海市嘉定区华江路348号1号楼707室
电话: +86 021 51069888
传真: +86 021 51069009
邮箱: zhang@yanatoo.com
网址: www.sensor-hbm.com

measure and predict with confidence

